

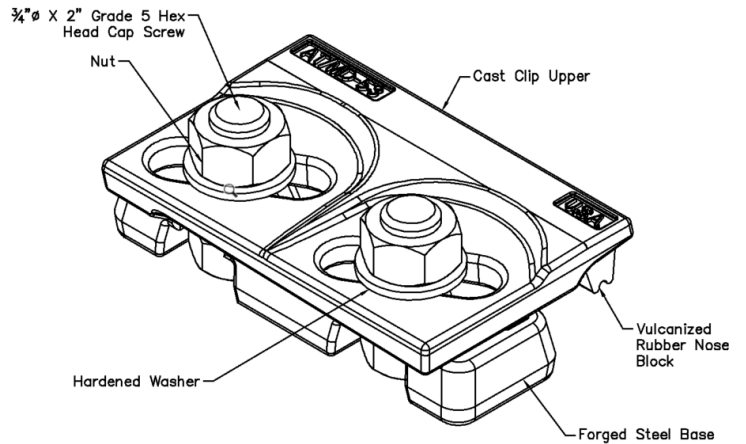

Clip Specifications	
Max Side Load Capacity:	53 Kips (235kN)
Horizontal Rail Adjustment	20mm (³ / ₄ ") Total
Approximate Clip Weight	6.2lbs (w/ Hardware)
Bolt Torque	259 ft/lbs



The Atlantic Track Mill Duty [MD]-53 Adjustable Crane Rail Clip is designed specifically to fix Crane Rail mounted on a narrow support beam or plate.

The low profile design allows this clip to be fitted on rail systems supporting cranes equipped with guide rollers.

- This proven design has been used successfully for many years throughout the world.
- The clip base is welded to the rail support. No access is required from below.
- The two components are locked together (structural friction connection) by properly torquing the grade 5 Hex Head Cap Screws.
- The clip has a self-tightening mechanism.
- A special vulcanized rubber nose block applies a controlled downforce to the rail.

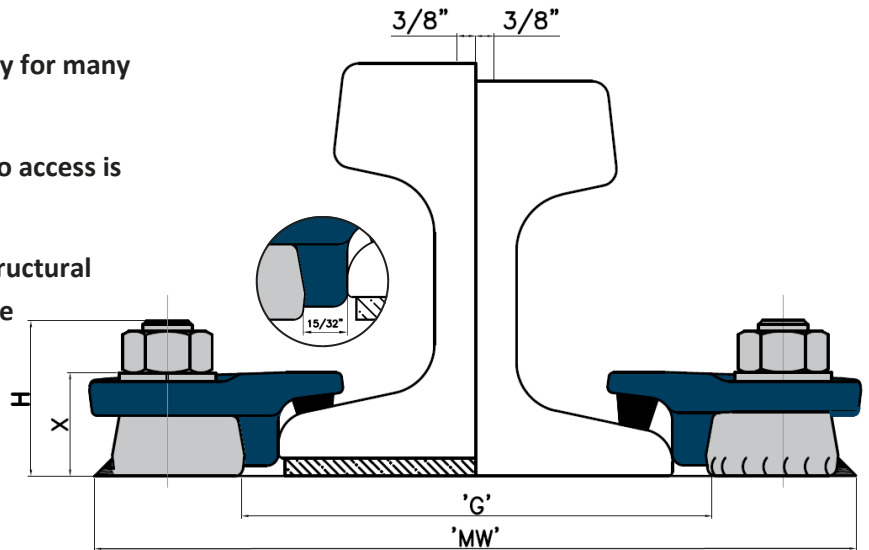

Assembly Dimensions	
Clip Gauge (G)	Rail Base + .945"
Minimum Mounting Width (MW)	Rail Base + 5.51"
Clip Dimensions	H = 2.375" X = 1.575"

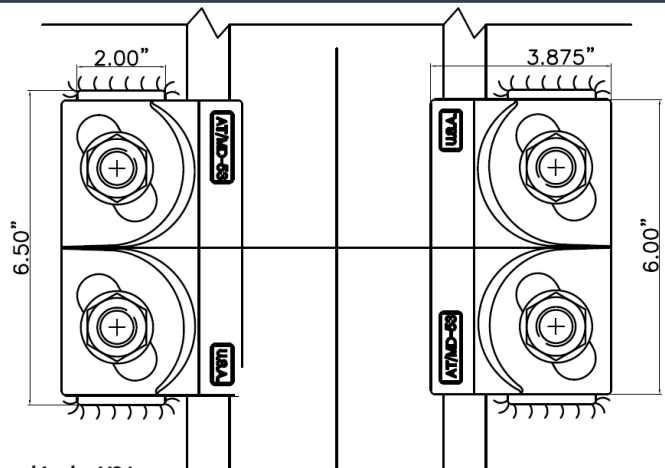

Engineered and Manufactured in the USA

1001 James Drive, Suite B37 • Leesport, PA 19533 • Phone: 610-916-2840 • Fax: 610-916-0898

Atlantic Track reserves the right to discontinue or change specifications or design at any time without prior notice and without incurring any obligation whatsoever.

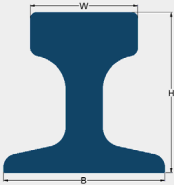

	Base (B) Inches	Height (H) Inches	Head Width (W) Inches	Suggested Minimum Mounting Width (MW) (Inches)	AT/MD-53 Pad Mounted	AT/MD-53 No Pad
ASCE 60	4¼	4¼	2¾	9¾	MD-53/60P	N/A
ASCE 80	5	5	2½	10½	MD-53/80P	N/A
ASCE 85	5 ³ / ₁₆	5 ³ / ₁₆	2 ⁹ / ₁₆	10⅝	MD-53/85P	N/A
104 CR (MRS51)	5	5	2½	10½	MD-53/104P	MD-53/104NP
105 CR (MRS52)	5 ³ / ₁₆	5 ³ / ₁₆	2 ⁹ / ₁₆	10⅝	MD-53/105P	MD-53/105NP
135 CR (MRS67)	5 ³ / ₁₆	5 ³ / ₁₆	3 ⁷ / ₁₆	10⅝	MD-53/135P	MD-53/135NP
171 CR (MRS85)	6	6	4.3	11½	MD-53/171P	MD-53/171NP
175 (MRS87B)	6	6	4¼	11½	MD-53/175P	MD-53/175NP
MRS87A	6	6	4	11½	MD-53/MRS87A-P	MD-53/MRS87A-NP
DIN A65	6.89	2.95	2.56	11⅜	MD-53/a65P	N/A
DIN A75	7.87	3.35	2.95	13⅜	MD-53/a75P	MD-53/a75NP
DIN A100	7.87	3.74	3.94	13⅜	MD-53/a100P	MD-53/a100NP
DIN A120	8.66	4.13	4.72	14⅜	MD-53/a120P	MD-53/a120NP
DIN A150	8.66	5.91	5.91	14⅜	MD-53/a150P	MD-53/a150NP

The Atlantic Track MD-Series Clips are available to suit most available rail sections. Please contact Atlantic Track if your rail does not appear in the above table.

Welding and Installation Guidelines

- Mark out and position clip base across rail centerline according to 'G' dimension on this Data Sheet.
- Weld all around the clip base with a 1/4" fillet weld, using low hydrogen electrodes. Recommended electrodes include AWS E7018 or E7028. Clip base is manufactured from weldable forged steel.

***For Clip Installation on systems without a Rail Pad, the weld closest to and parallel with the rail must be adapted or omitted. Please contact Atlantic Track for additional weld detail when pad is not to be used.**

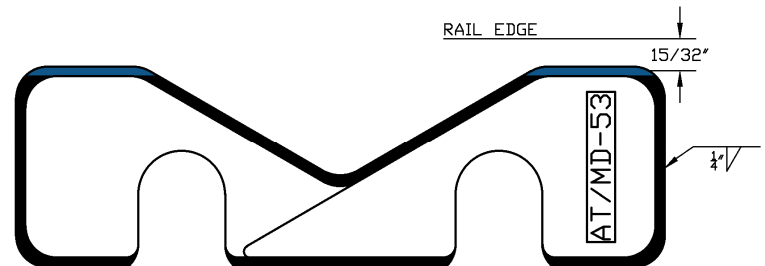

- Do not apply coatings to the contact surface between upper and lower components. Consult with Atlantic Track prior to painting or coating any component.
- For complete installation guidelines, please contact Atlantic Track for the applicable Technical Bulletin.

Engineered and Manufactured in the USA

1001 James Drive, Suite B37 • Leesport, PA 19533 • Phone: 610-916-2840 • Fax: 610-916-0898

Atlantic Track reserves the right to discontinue or change specifications or design at any time without prior notice and without incurring any obligation whatsoever.